

# Unit 2/11 Dunbavan Place

## Ground Floor

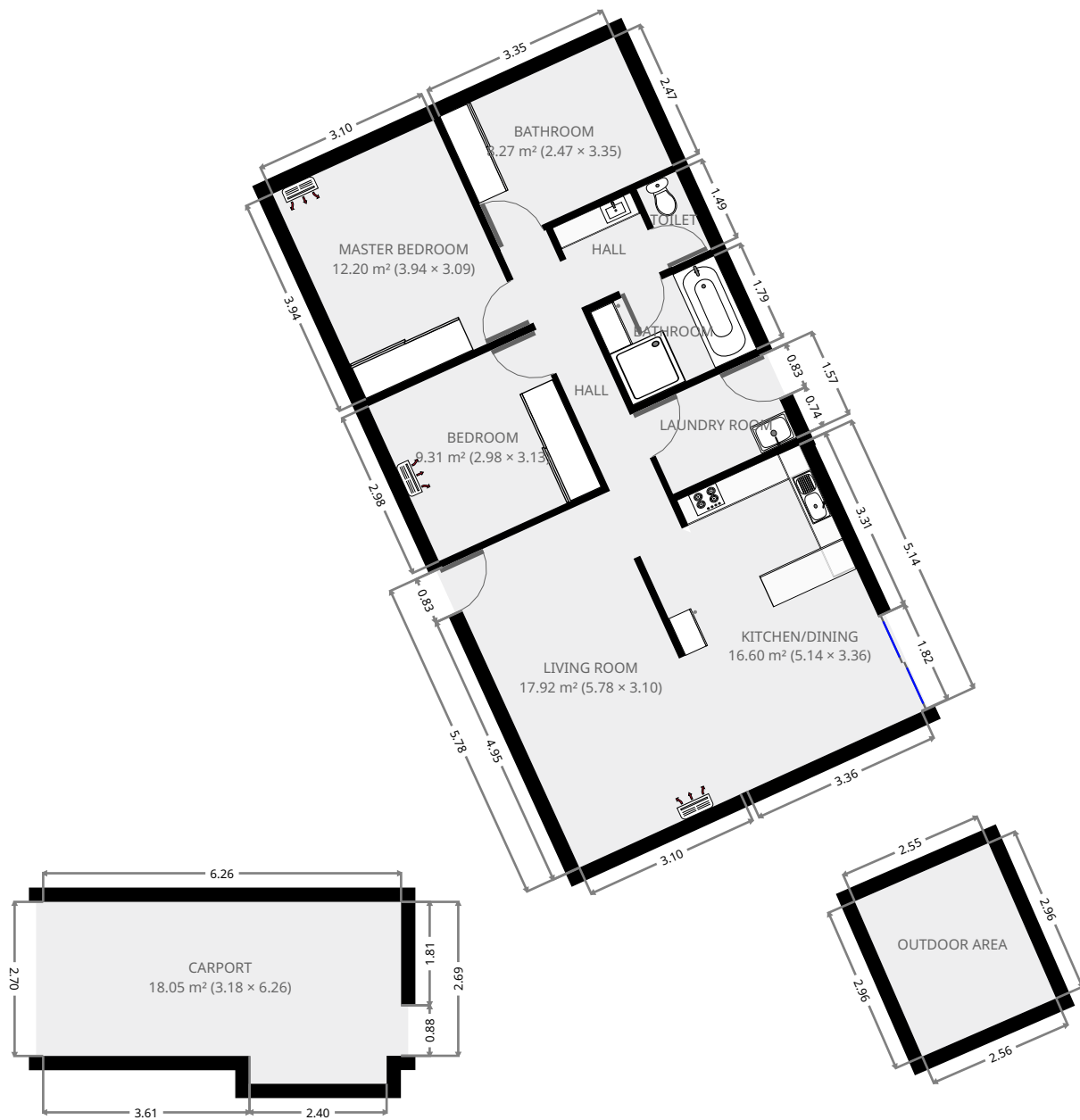

THIS FLOORPLAN IS PROVIDED WITHOUT WARRANTY OF ANY KIND. SENSOPIA DISCLAIMS ANY WARRANTY INCLUDING, WITHOUT LIMITATION, SATISFACTORY QUALITY OR ACCURACY OF DIMENSIONS.



# Unit 2/11 Dunbavan Place

## Living Room

Width: 3.10 m  
 Length: 5.78 m  
 Area: 17.92 m<sup>2</sup>  
 Perimeter: 17.76 m

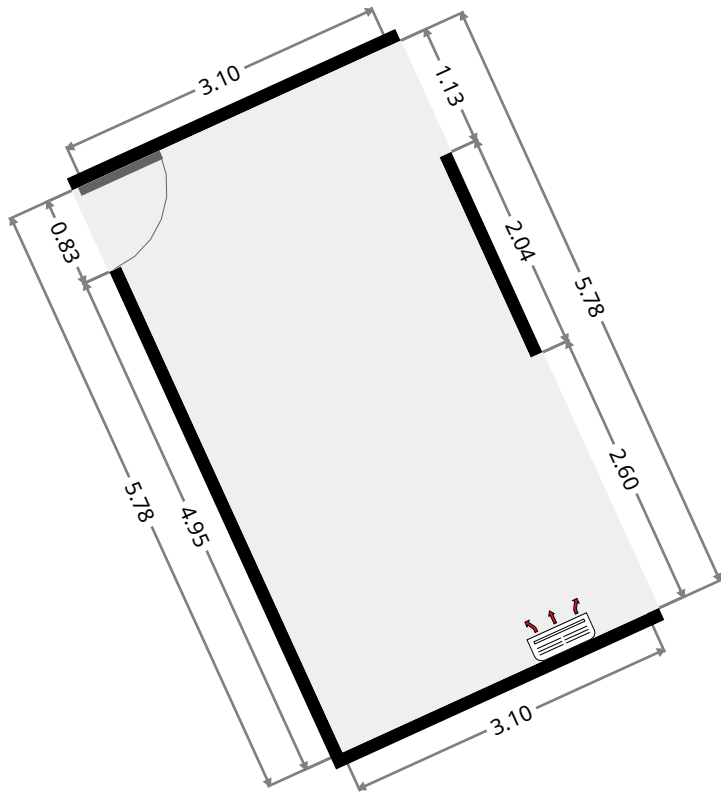

## Kitchen/Dining

Width: 3.36 m  
 Length: 5.14 m  
 Area: 16.60 m<sup>2</sup>  
 Perimeter: 16.97 m

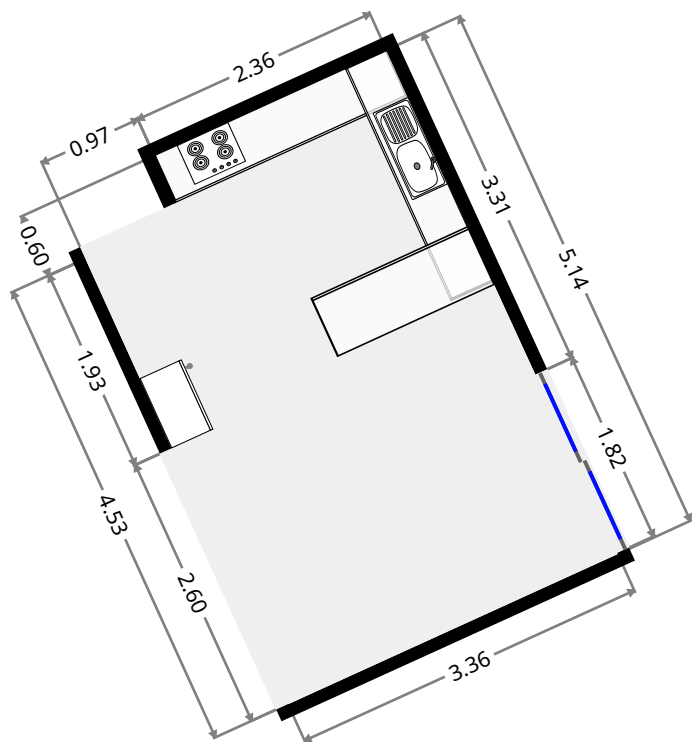
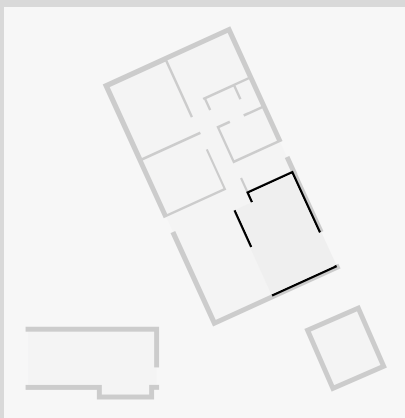

THIS FLOORPLAN IS PROVIDED WITHOUT WARRANTY OF ANY KIND. SENSOPIA DISCLAIMS ANY WARRANTY INCLUDING, WITHOUT LIMITATION, SATISFACTORY QUALITY OR ACCURACY OF DIMENSIONS.

# Unit 2/11 Dunbavan Place

## Hall

Width: 0.87 m  
 Length: 5.75 m  
 Area: 4.99 m<sup>2</sup>  
 Perimeter: 13.23 m

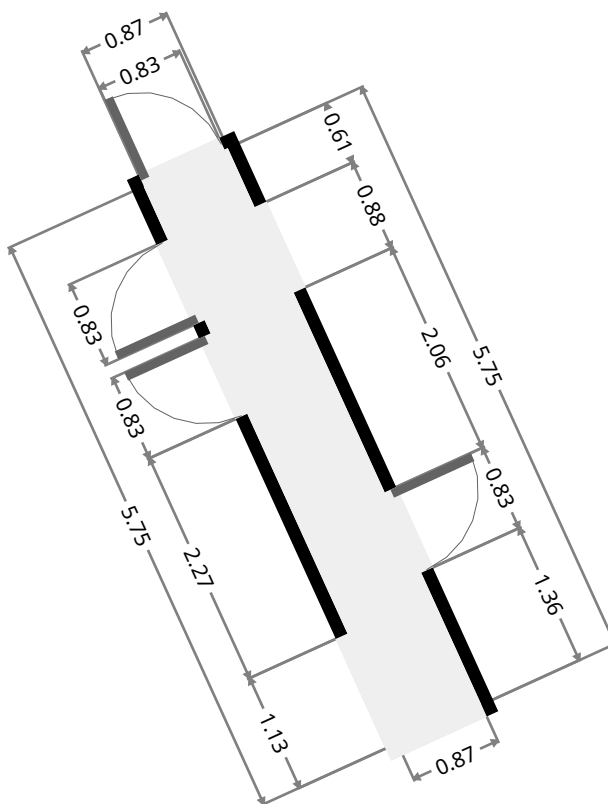
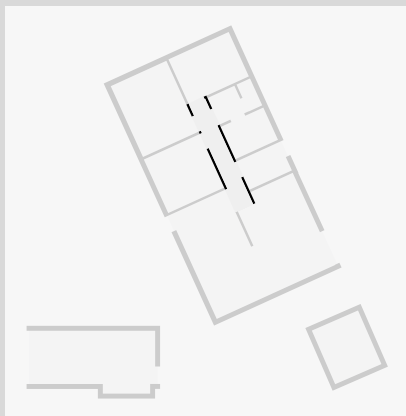

## Laundry Room

Width: 1.57 m  
 Length: 2.38 m  
 Area: 3.74 m<sup>2</sup>  
 Perimeter: 7.90 m

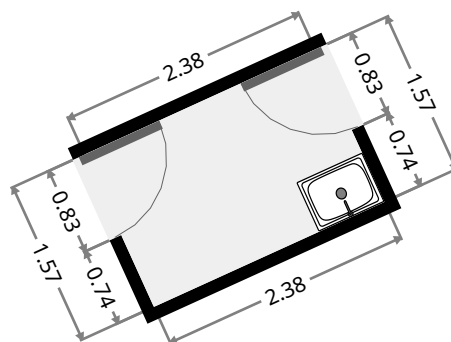
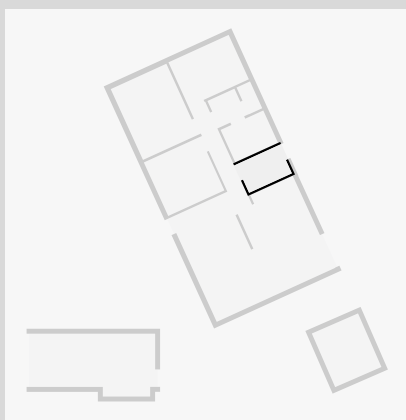

THIS FLOORPLAN IS PROVIDED WITHOUT WARRANTY OF ANY KIND. SENSOPIA DISCLAIMS ANY WARRANTY INCLUDING, WITHOUT LIMITATION, SATISFACTORY QUALITY OR ACCURACY OF DIMENSIONS.



# Unit 2/11 Dunbavan Place

## Bedroom

Width: 2.98 m  
Length: 3.13 m  
Area: 9.31 m<sup>2</sup>  
Perimeter: 12.21 m

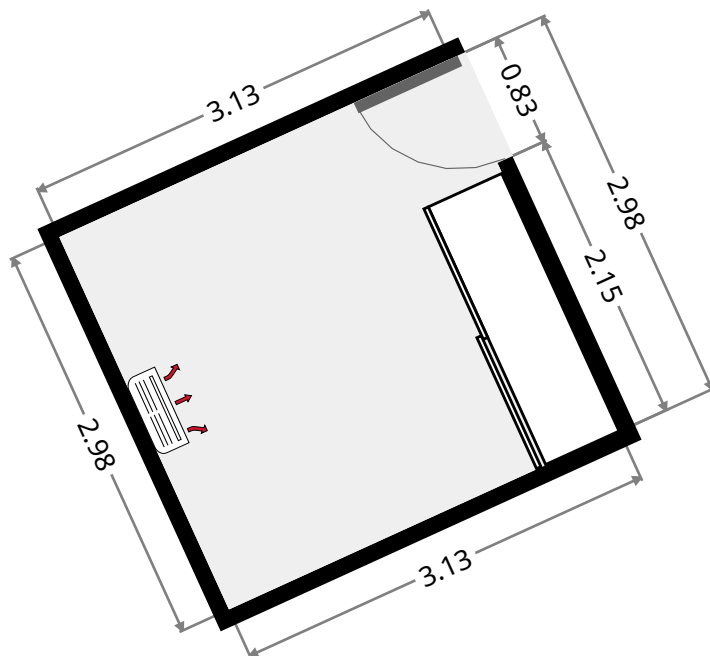
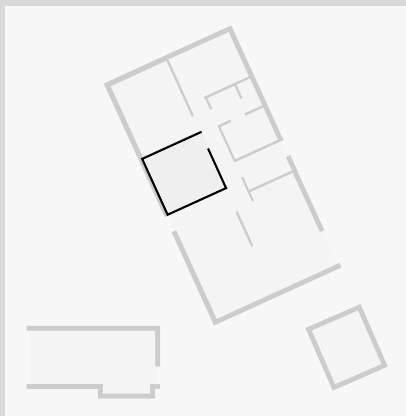

## Master Bedroom

Width: 3.09 m  
Length: 3.94 m  
Area: 12.20 m<sup>2</sup>  
Perimeter: 14.07 m

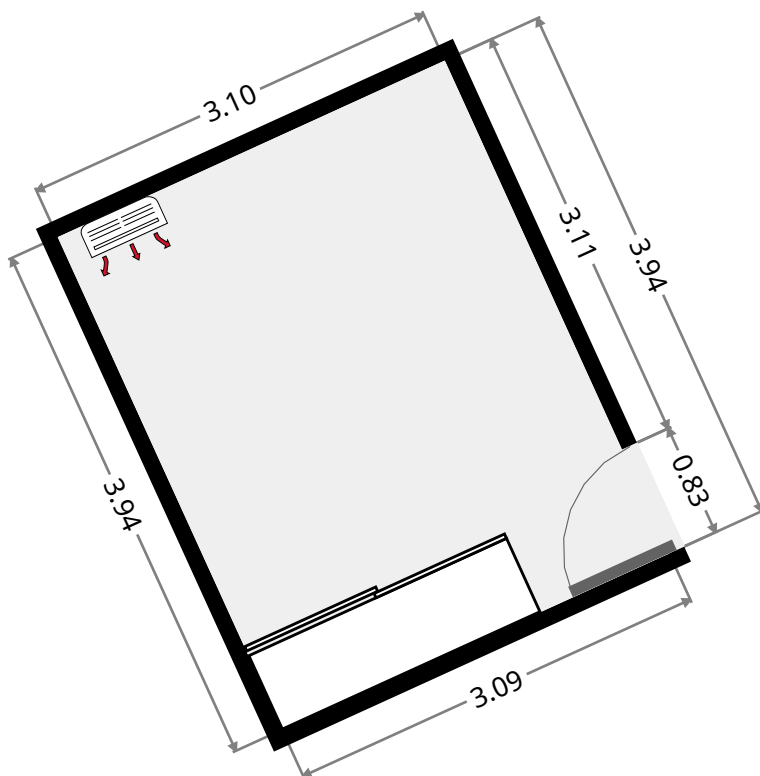
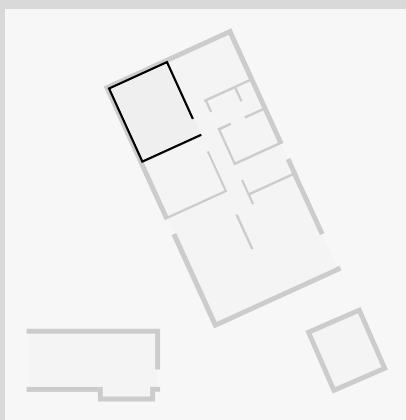

THIS FLOORPLAN IS PROVIDED WITHOUT WARRANTY OF ANY KIND. SENSOPIA DISCLAIMS ANY WARRANTY INCLUDING, WITHOUT LIMITATION, SATISFACTORY QUALITY OR ACCURACY OF DIMENSIONS.

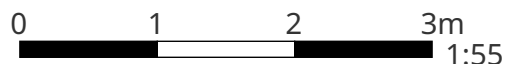

# Unit 2/11 Dunbavan Place

## Bathroom

Width: 2.47 m  
 Length: 3.35 m  
 Area: 8.27 m<sup>2</sup>  
 Perimeter: 11.64 m

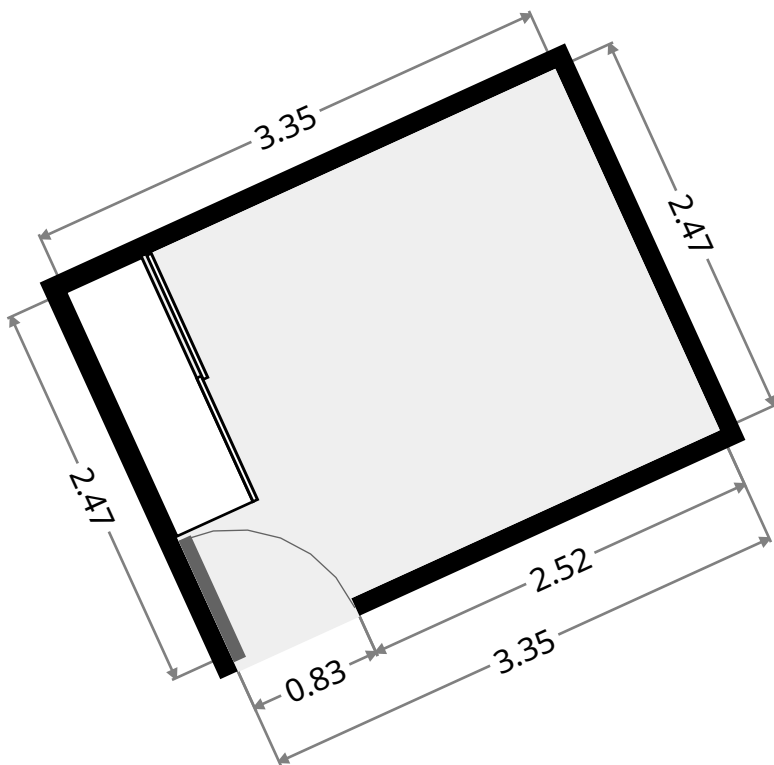
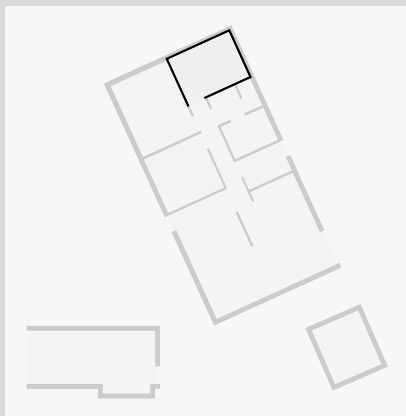

## Hall

Width: 1.48 m  
 Length: 1.50 m  
 Area: 2.22 m<sup>2</sup>  
 Perimeter: 5.96 m

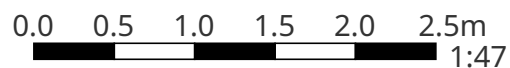
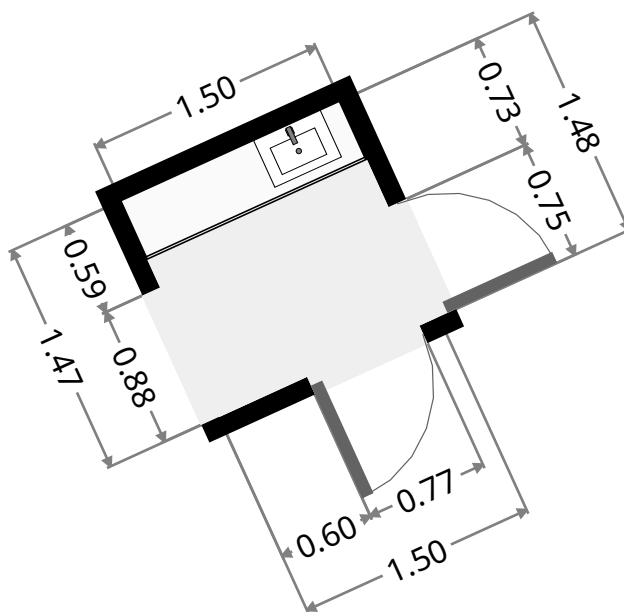
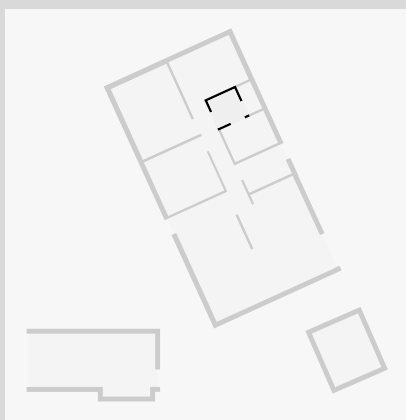

THIS FLOORPLAN IS PROVIDED WITHOUT WARRANTY OF ANY KIND. SENSOPIA DISCLAIMS ANY WARRANTY INCLUDING, WITHOUT LIMITATION, SATISFACTORY QUALITY OR ACCURACY OF DIMENSIONS.

# Unit 2/11 Dunbavan Place

## Bathroom

Width: 1.79 m  
Length: 2.38 m  
Area: 4.27 m<sup>2</sup>  
Perimeter: 8.35 m

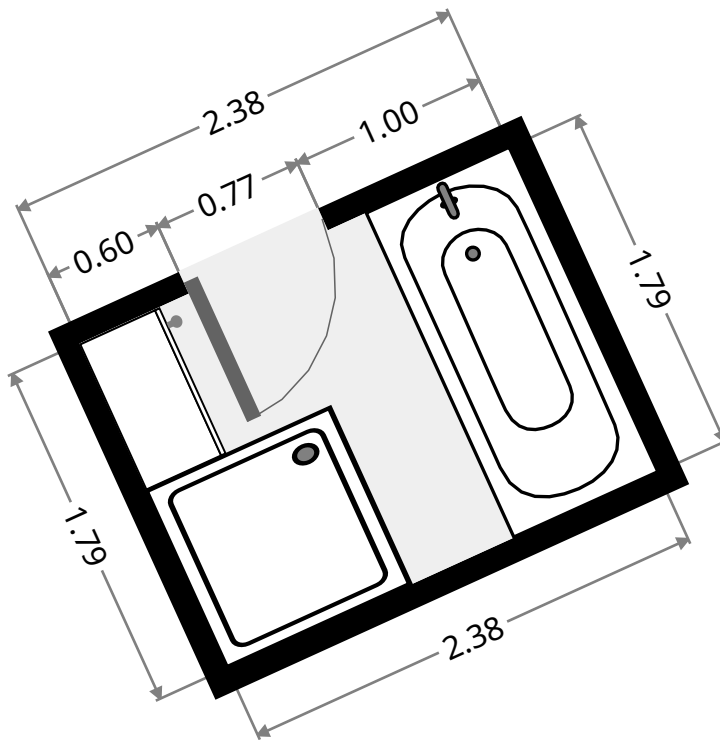
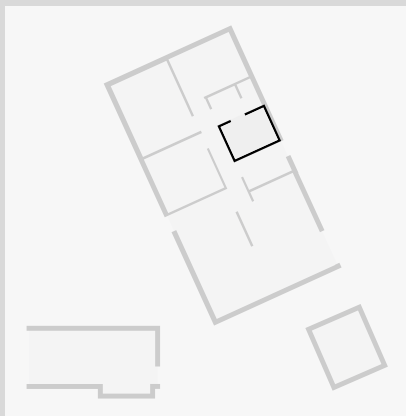

## Toilet

Width: 0.75 m  
Length: 1.49 m  
Area: 1.12 m<sup>2</sup>  
Perimeter: 4.49 m

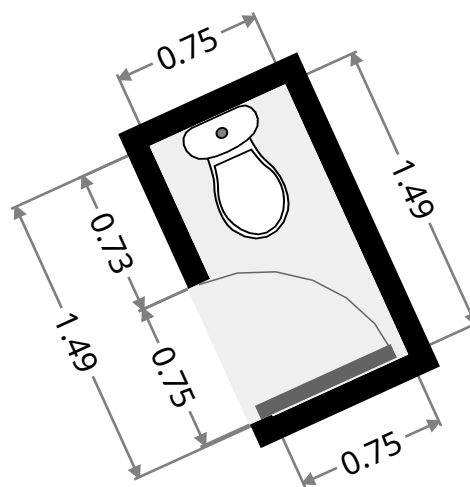
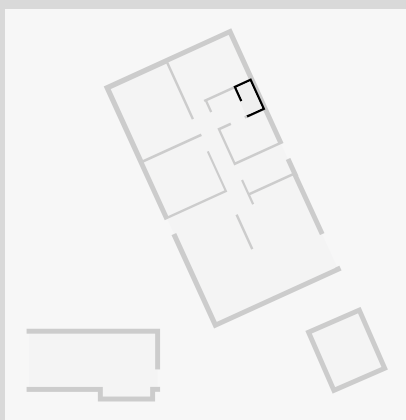

THIS FLOORPLAN IS PROVIDED WITHOUT WARRANTY OF ANY KIND. SENSOPIA DISCLAIMS ANY WARRANTY INCLUDING, WITHOUT LIMITATION, SATISFACTORY QUALITY OR ACCURACY OF DIMENSIONS.

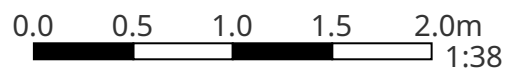

# Unit 2/11 Dunbavan Place

## Carport

Width: 3.18 m  
Length: 6.26 m  
Area: 18.05 m<sup>2</sup>  
Perimeter: 18.89 m

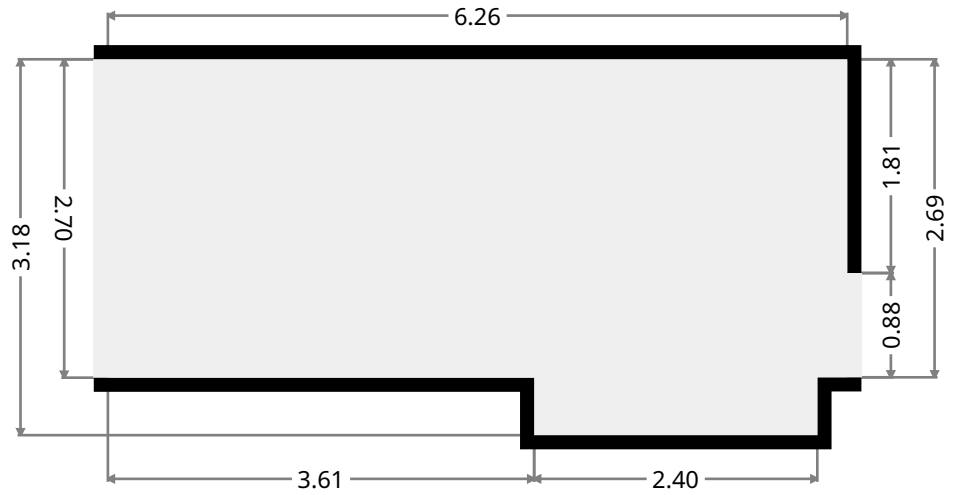
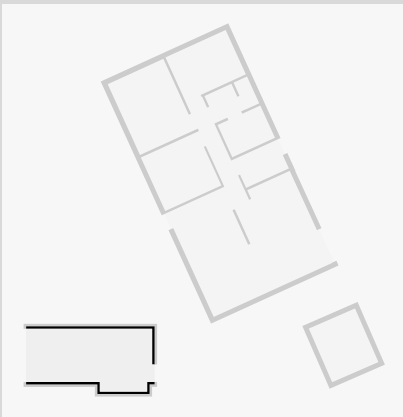

## Outdoor Area

Width: 2.56 m  
Length: 2.96 m  
Area: 7.56 m<sup>2</sup>  
Perimeter: 11.03 m

