

449 Eichelberger Street

Ground Floor

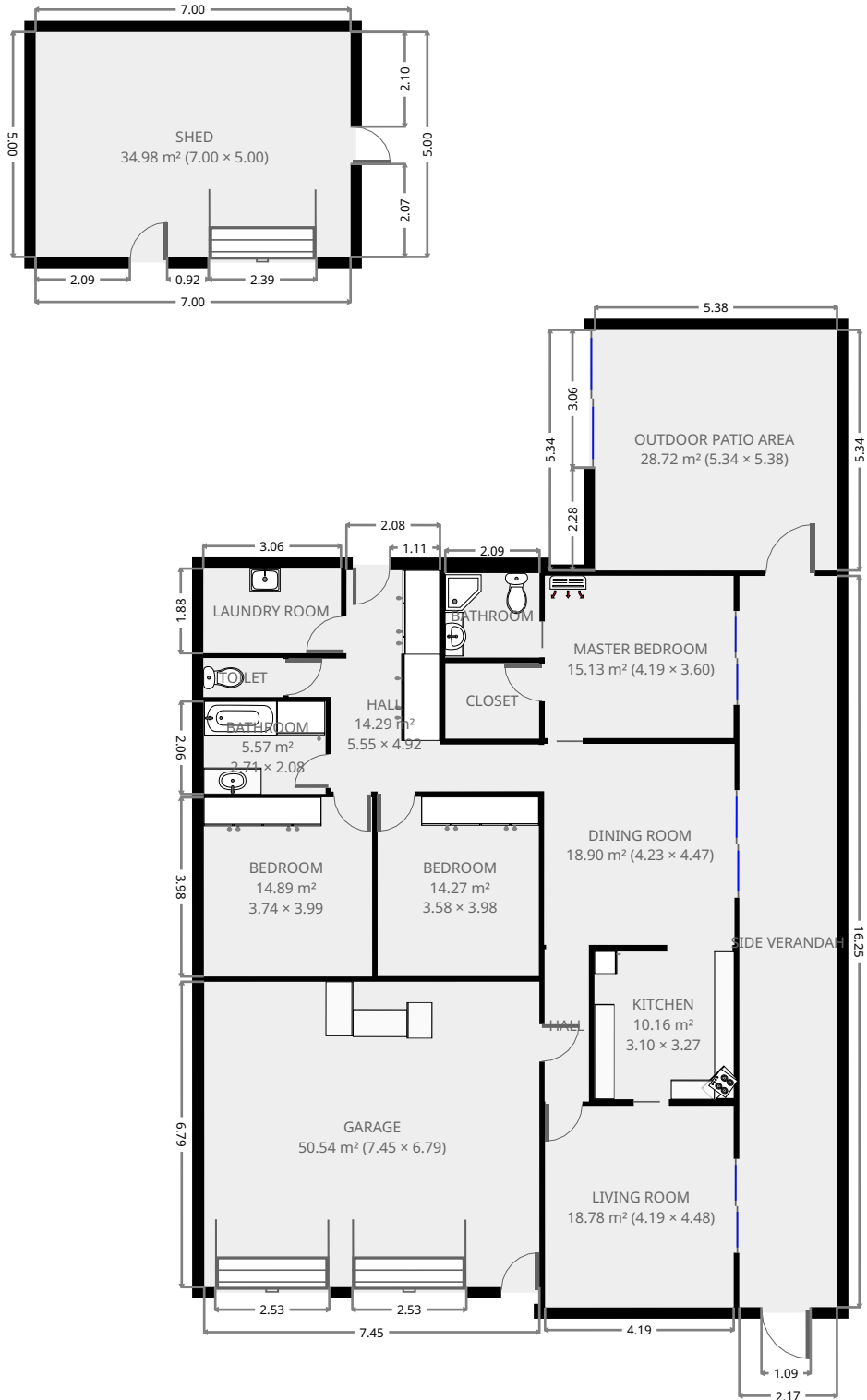

THIS FLOORPLAN IS PROVIDED WITHOUT WARRANTY OF ANY KIND. SENSOPIA DISCLAIMS ANY WARRANTY INCLUDING, WITHOUT LIMITATION, SATISFACTORY QUALITY OR ACCURACY OF DIMENSIONS.



449 Eichelberger Street

Hall

Width: 4.92 m
 Length: 5.55 m
 Area: 14.29 m²
 Perimeter: 20.94 m

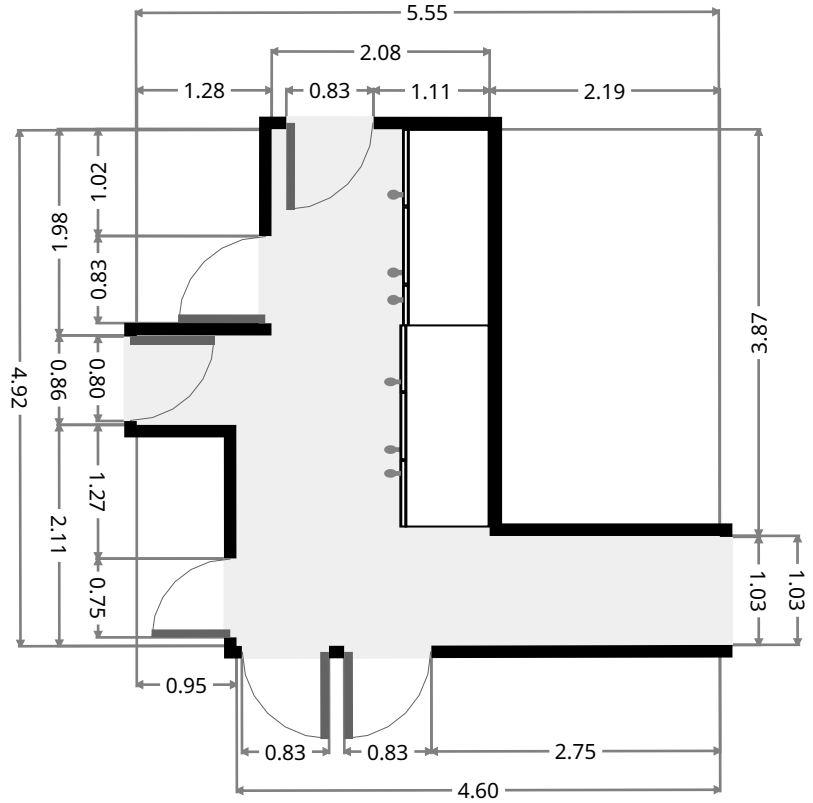
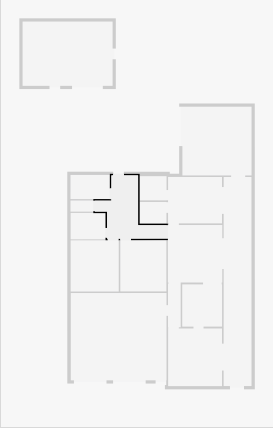

Shed

Width: 5.00 m
 Length: 7.00 m
 Area: 34.98 m²
 Perimeter: 23.99 m

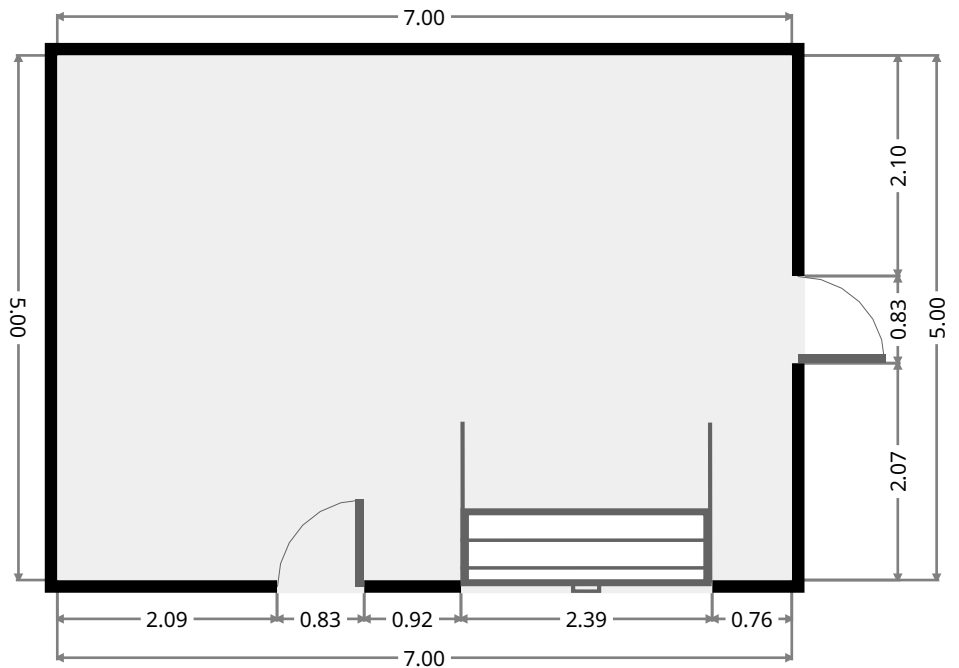
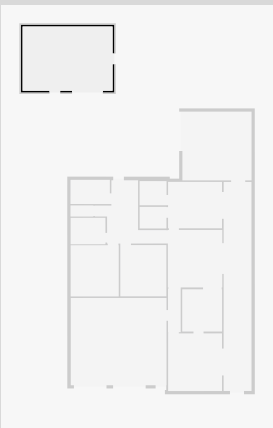

THIS FLOORPLAN IS PROVIDED WITHOUT WARRANTY OF ANY KIND. SENSOPIA DISCLAIMS ANY WARRANTY INCLUDING, WITHOUT LIMITATION, SATISFACTORY QUALITY OR ACCURACY OF DIMENSIONS.

449 Eichelberger Street

Outdoor Patio Area

Width: 5.34 m
Length: 5.38 m
Area: 28.72 m²
Perimeter: 21.44 m

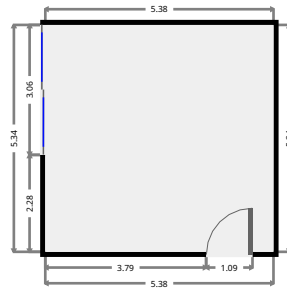
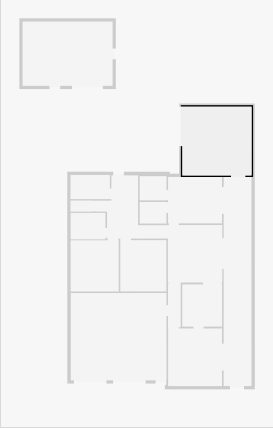

Side Verandah

Width: 2.16 m
Length: 16.25 m
Area: 35.18 m²
Perimeter: 36.83 m

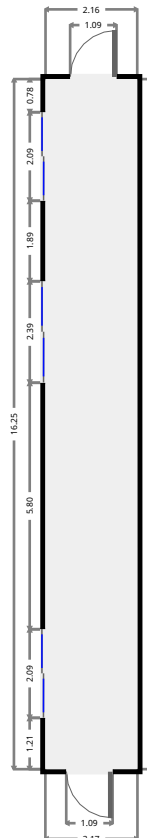
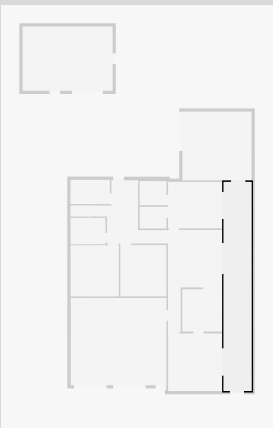

449 Eichelberger Street

Laundry Room

Width: 1.89 m
Length: 3.06 m
Area: 5.76 m²
Perimeter: 9.88 m

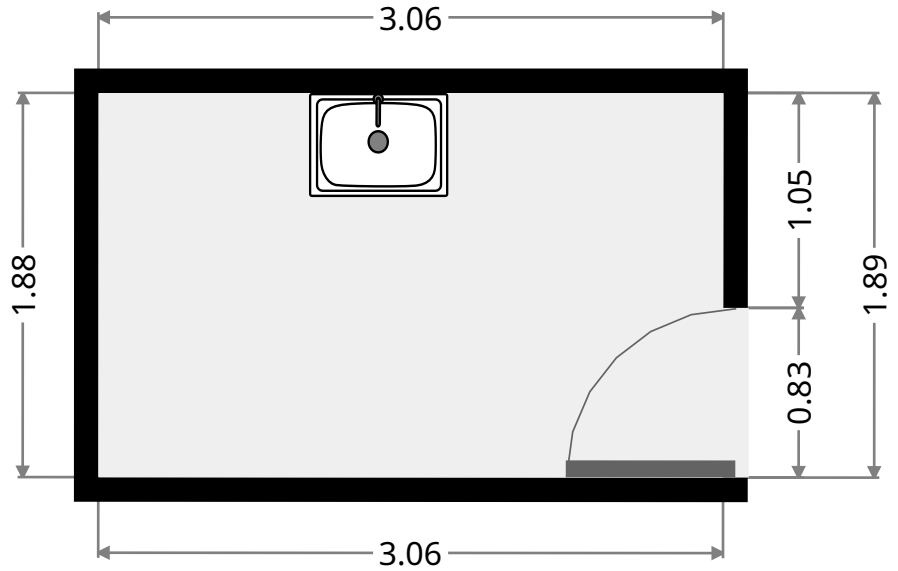
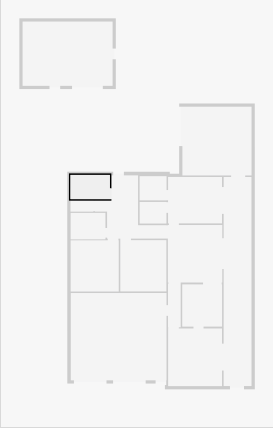

Toilet

Width: 0.87 m
Length: 1.78 m
Area: 1.54 m²
Perimeter: 5.29 m

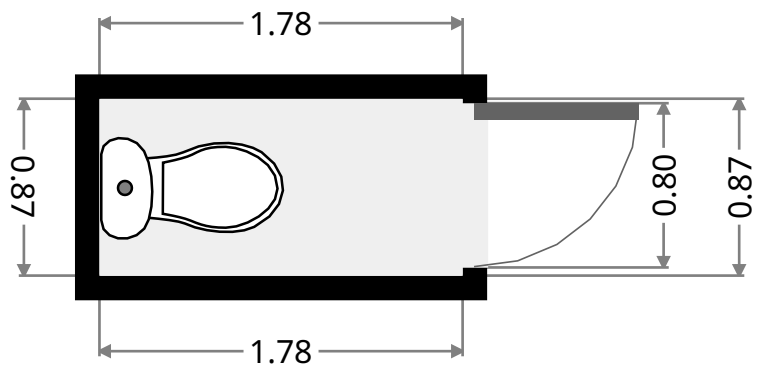
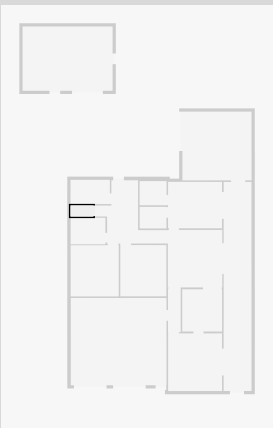

449 Eichelberger Street

Bathroom

Width: 2.08 m
Length: 2.71 m
Area: 5.57 m²
Perimeter: 9.53 m

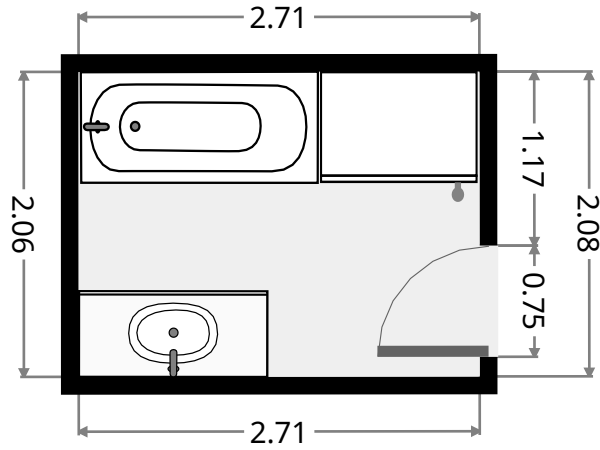

Bedroom

Width: 3.74 m
Length: 3.99 m
Area: 14.89 m²
Perimeter: 15.44 m

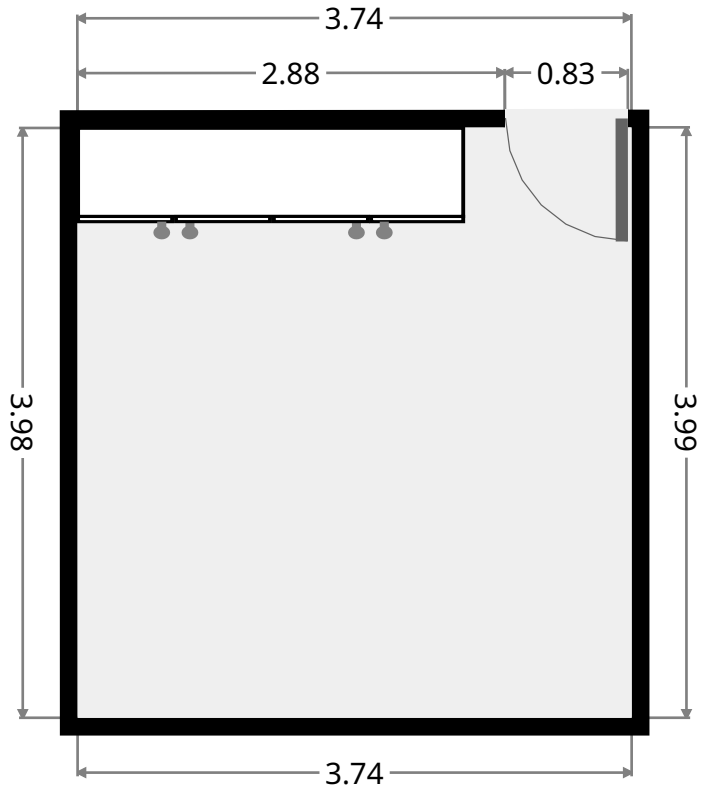

449 Eichelberger Street

Bedroom

Width: 3.58 m
 Length: 3.98 m
 Area: 14.27 m²
 Perimeter: 15.13 m

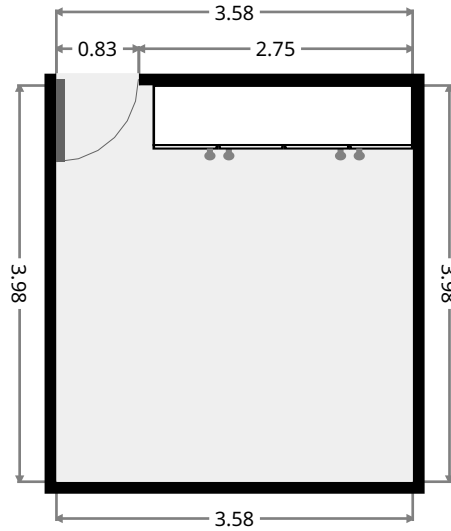
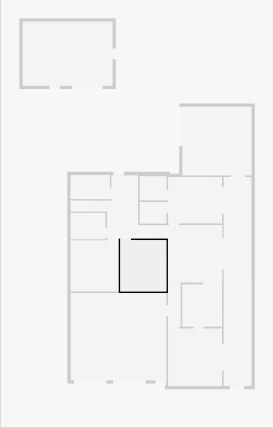

Garage

Width: 6.79 m
 Length: 7.45 m
 Area: 50.54 m²
 Perimeter: 28.47 m

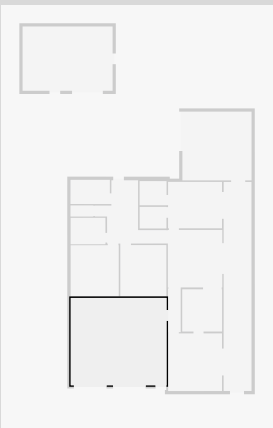

THIS FLOORPLAN IS PROVIDED WITHOUT WARRANTY OF ANY KIND. SENSOPIA DISCLAIMS ANY WARRANTY INCLUDING, WITHOUT LIMITATION, SATISFACTORY QUALITY OR ACCURACY OF DIMENSIONS.

449 Eichelberger Street

Closet

Width: 1.68 m
Length: 2.08 m
Area: 3.49 m²
Perimeter: 7.52 m

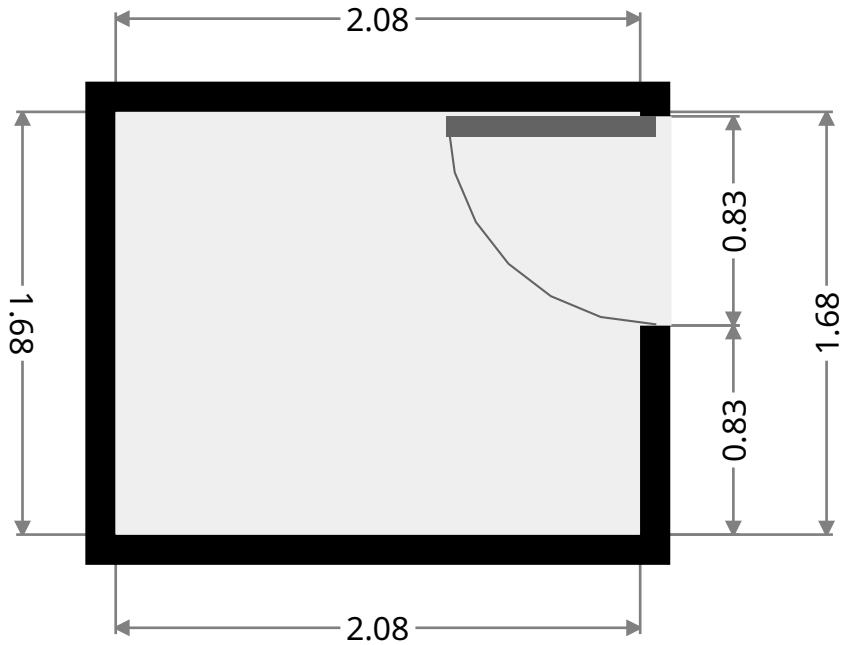
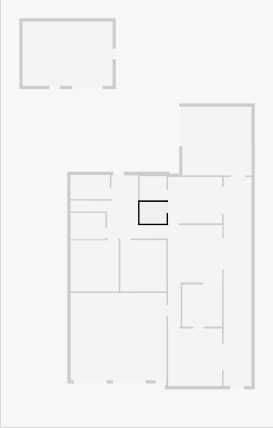

Bathroom

Width: 1.88 m
Length: 2.09 m
Area: 3.93 m²
Perimeter: 7.94 m

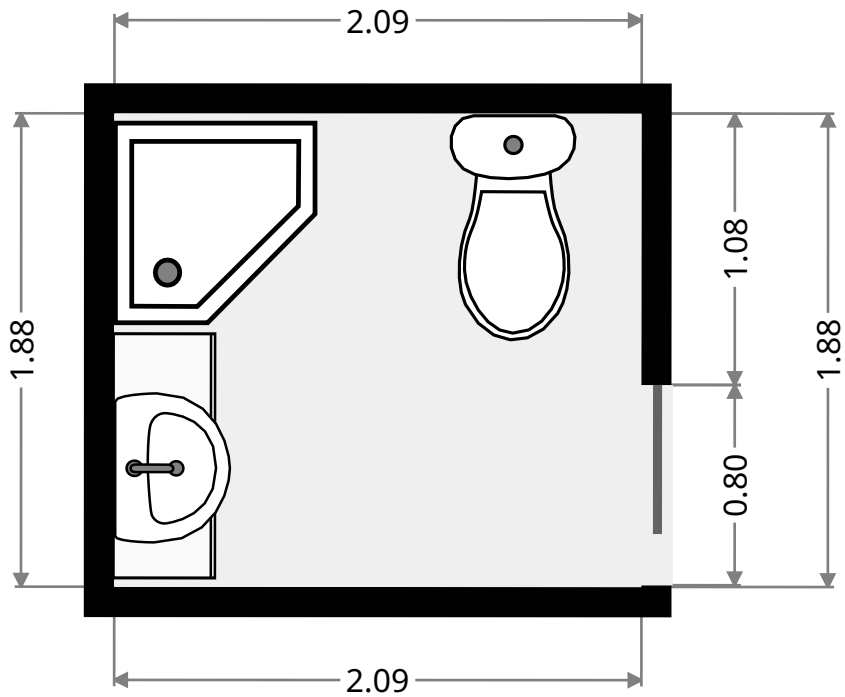
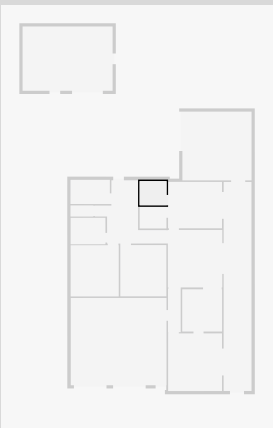

THIS FLOORPLAN IS PROVIDED WITHOUT WARRANTY OF ANY KIND. SENSOPIA DISCLAIMS ANY WARRANTY INCLUDING, WITHOUT LIMITATION, SATISFACTORY QUALITY OR ACCURACY OF DIMENSIONS.

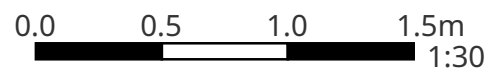

449 Eichelberger Street

Master Bedroom

Width: 3.60 m
 Length: 4.19 m
 Area: 15.13 m²
 Perimeter: 15.60 m

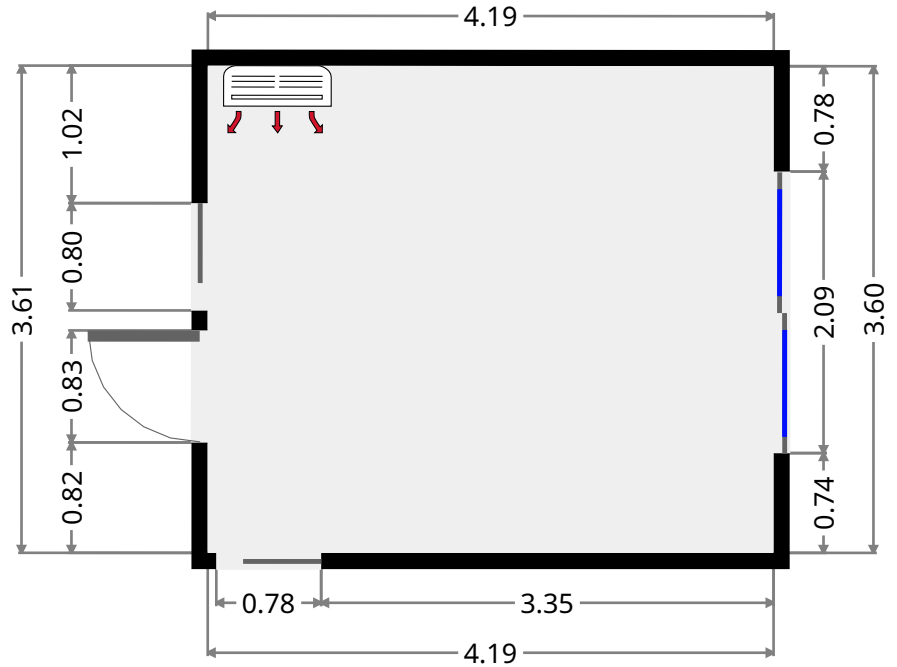
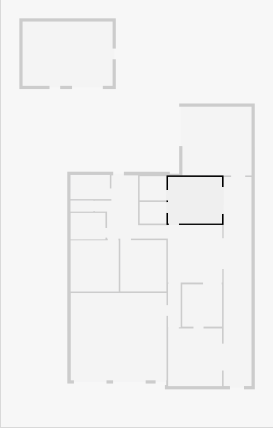

Living Room

Width: 4.19 m
 Length: 4.48 m
 Area: 18.78 m²
 Perimeter: 17.35 m

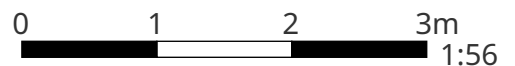
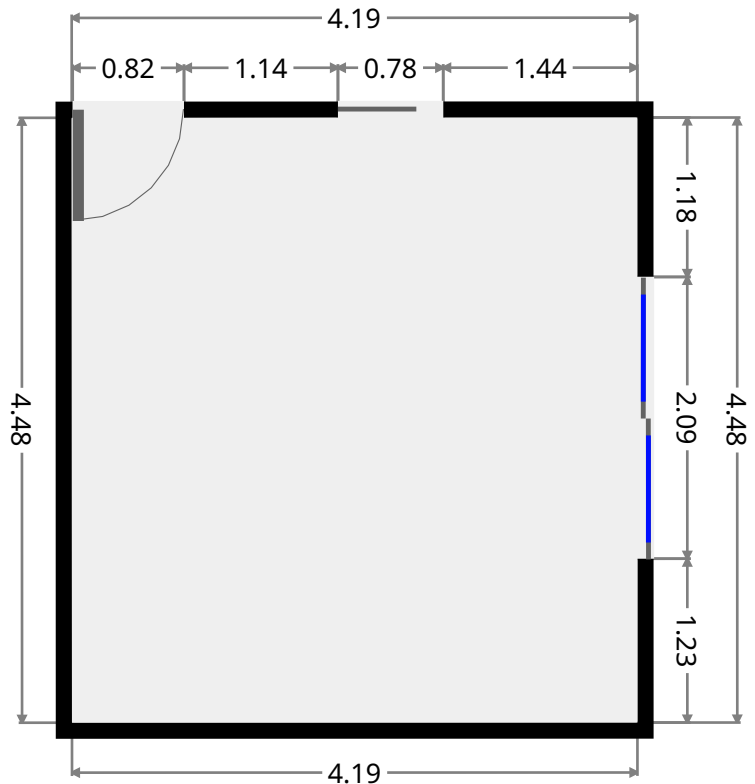
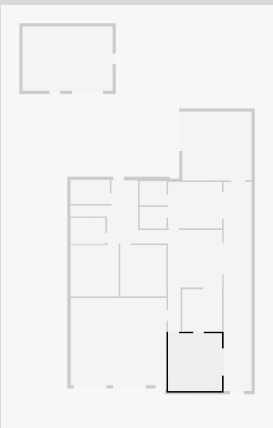

THIS FLOORPLAN IS PROVIDED WITHOUT WARRANTY OF ANY KIND. SENSOPIA DISCLAIMS ANY WARRANTY INCLUDING, WITHOUT LIMITATION, SATISFACTORY QUALITY OR ACCURACY OF DIMENSIONS.

449 Eichelberger Street

Kitchen

Width: 3.10 m
 Length: 3.27 m
 Area: 10.16 m²
 Perimeter: 12.76 m

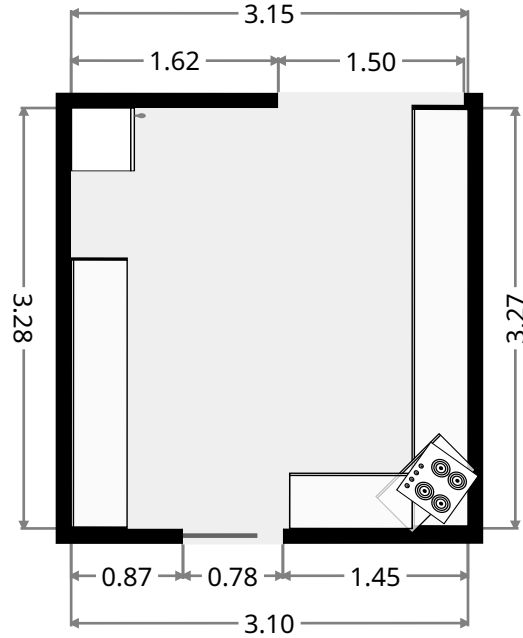
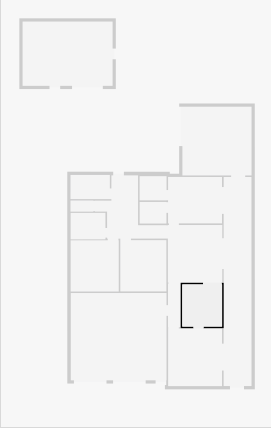

Dining Room

Width: 4.23 m
 Length: 4.47 m
 Area: 18.90 m²
 Perimeter: 17.40 m

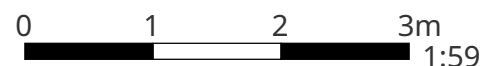
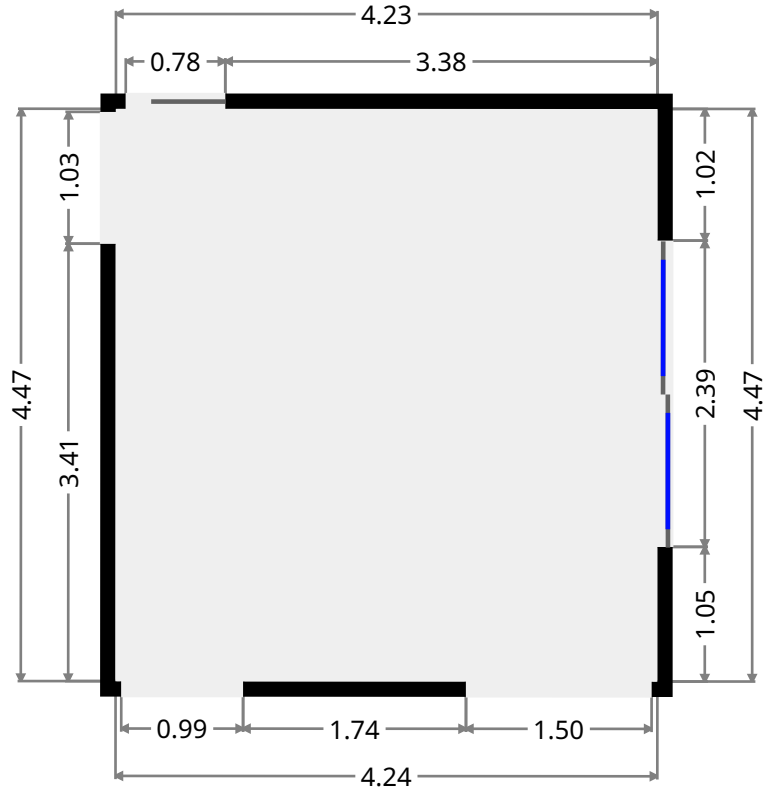
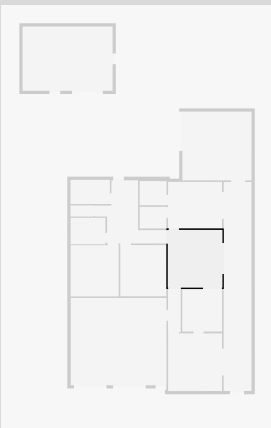

THIS FLOORPLAN IS PROVIDED WITHOUT WARRANTY OF ANY KIND. SENSOPIA DISCLAIMS ANY WARRANTY INCLUDING, WITHOUT LIMITATION, SATISFACTORY QUALITY OR ACCURACY OF DIMENSIONS.

449 Eichelberger Street

Hall

Width: 0.99 m
Length: 3.39 m
Area: 3.33 m²
Perimeter: 8.74 m

