

311 Waterloo Street

Ground Floor

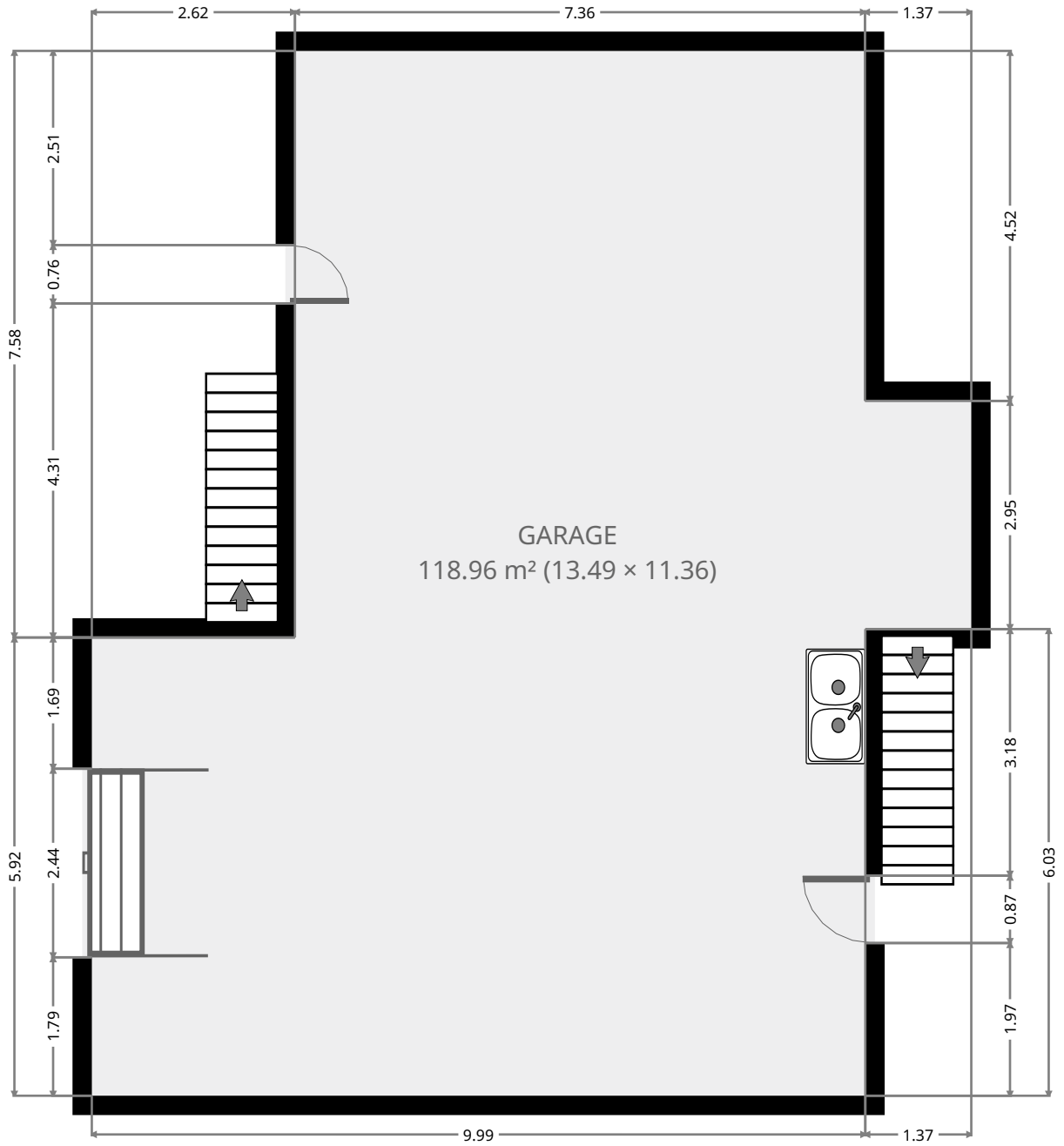

THIS FLOORPLAN IS PROVIDED WITHOUT WARRANTY OF ANY KIND. SENSOPIA DISCLAIMS ANY WARRANTY INCLUDING, WITHOUT LIMITATION, SATISFACTORY QUALITY OR ACCURACY OF DIMENSIONS.



311 Waterloo Street

Garage

Width: 11.36 m
Length: 13.49 m
Area: 118.96 m²
Perimeter: 49.71 m

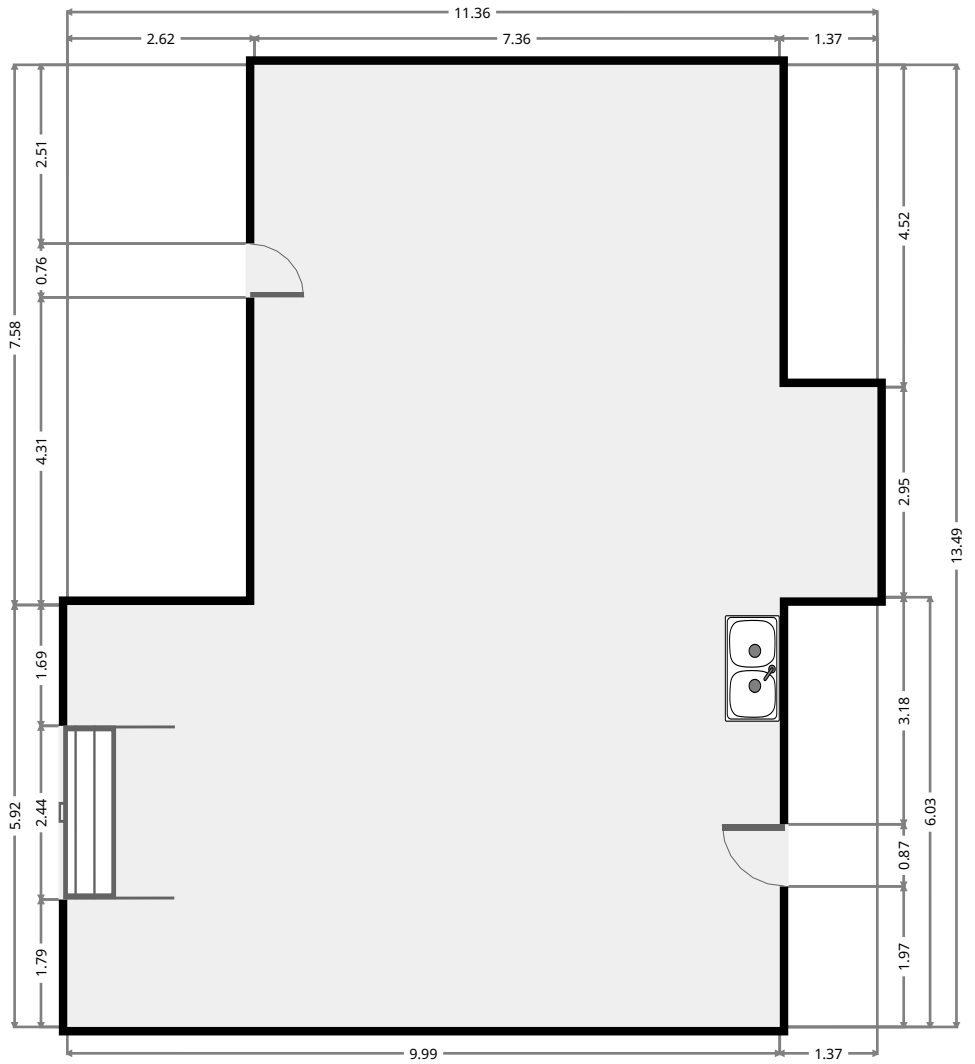
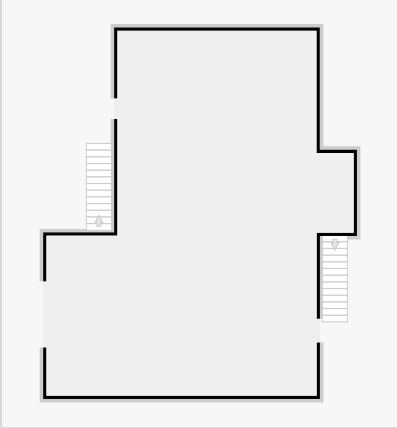

THIS FLOORPLAN IS PROVIDED WITHOUT WARRANTY OF ANY KIND. SENSOPIA DISCLAIMS ANY WARRANTY INCLUDING, WITHOUT LIMITATION, SATISFACTORY QUALITY OR ACCURACY OF DIMENSIONS.



311 Waterloo Street

1st Floor

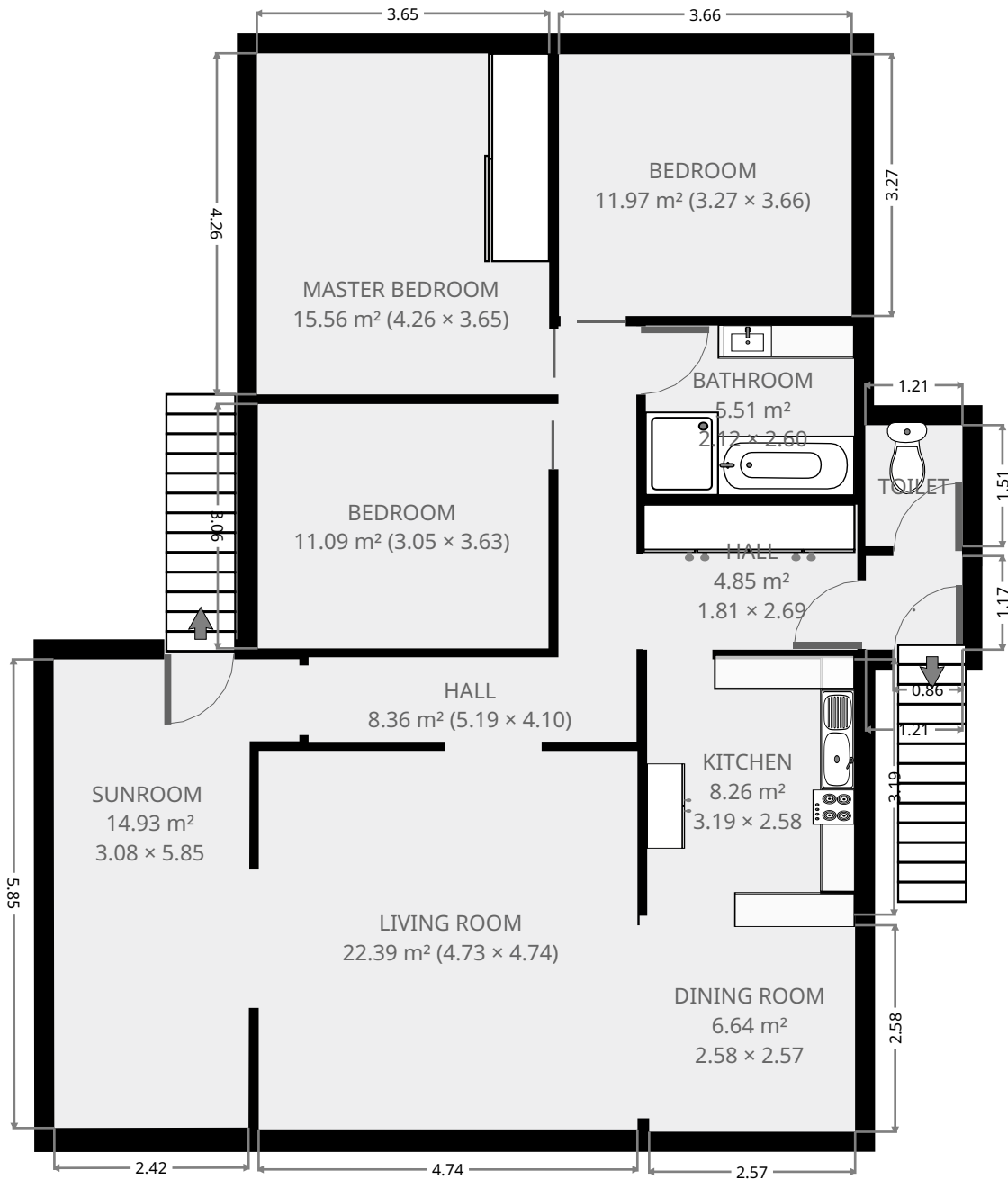

THIS FLOORPLAN IS PROVIDED WITHOUT WARRANTY OF ANY KIND. SENSOPIA DISCLAIMS ANY WARRANTY INCLUDING, WITHOUT LIMITATION, SATISFACTORY QUALITY OR ACCURACY OF DIMENSIONS.



311 Waterloo Street

Sunroom

Width: 3.08 m
 Length: 5.85 m
 Area: 14.93 m²
 Perimeter: 17.83 m

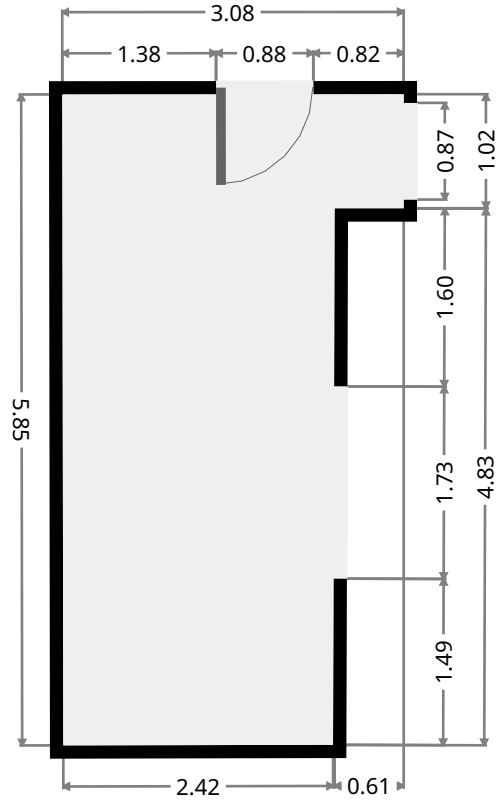
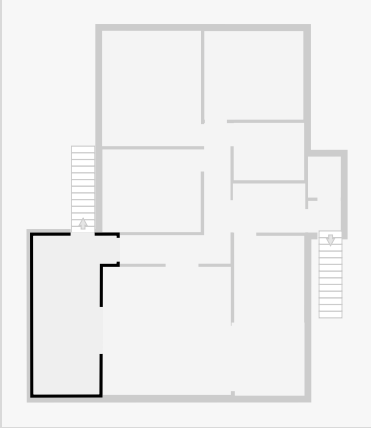

Living Room

Width: 4.73 m
 Length: 4.74 m
 Area: 22.39 m²
 Perimeter: 18.93 m

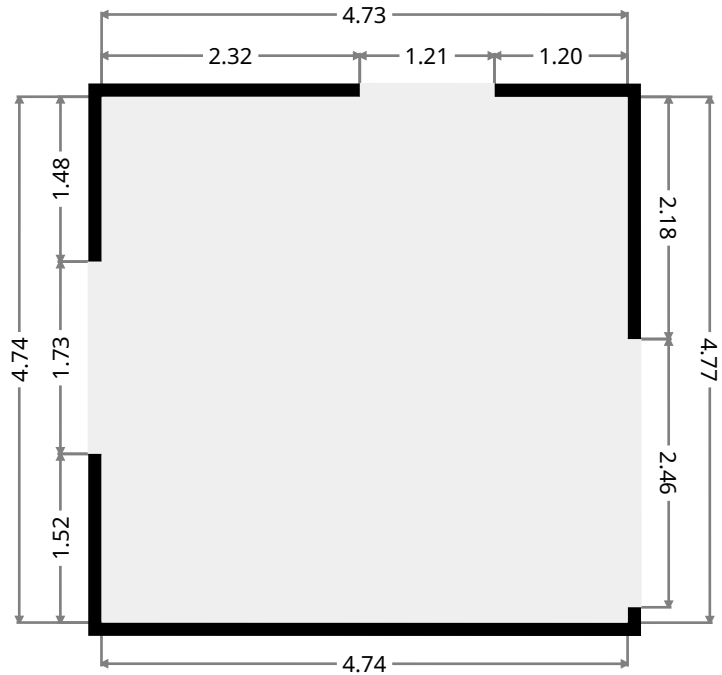
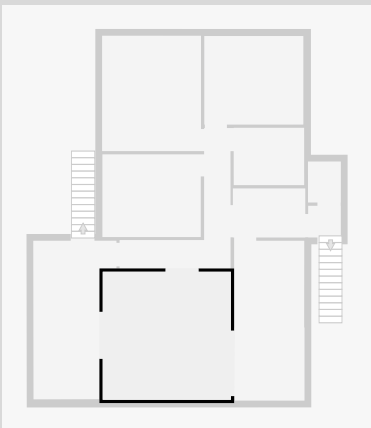

THIS FLOORPLAN IS PROVIDED WITHOUT WARRANTY OF ANY KIND. SENSOPIA DISCLAIMS ANY WARRANTY INCLUDING, WITHOUT LIMITATION, SATISFACTORY QUALITY OR ACCURACY OF DIMENSIONS.

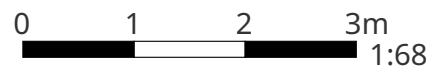

311 Waterloo Street

Hall

Width: 4.10 m
 Length: 5.19 m
 Area: 8.36 m²
 Perimeter: 18.58 m

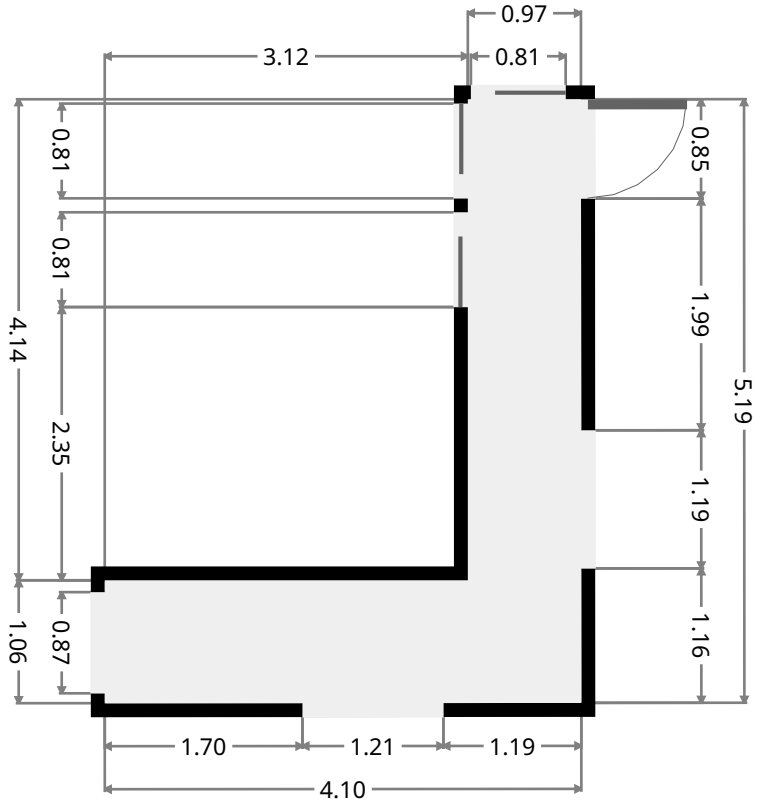
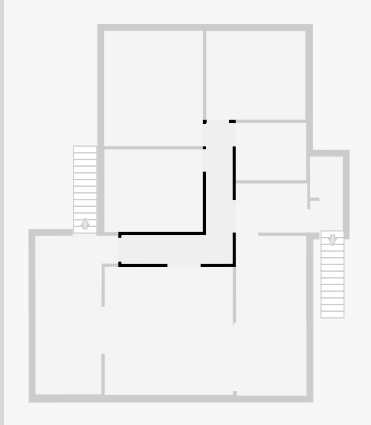

Dining Room

Width: 2.57 m
 Length: 2.58 m
 Area: 6.64 m²
 Perimeter: 10.31 m

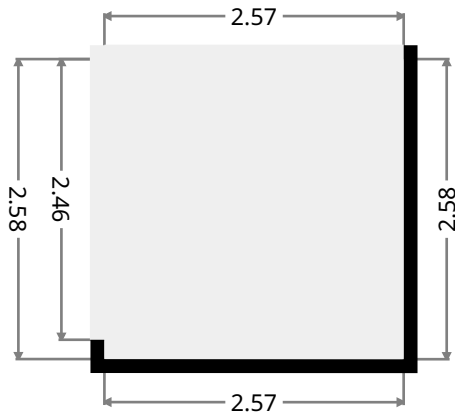
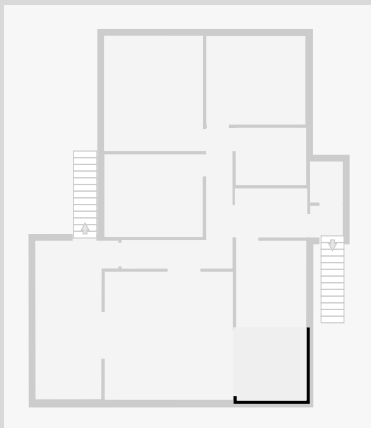

311 Waterloo Street

Kitchen

Width: 2.58 m
 Length: 3.19 m
 Area: 8.26 m²
 Perimeter: 11.56 m

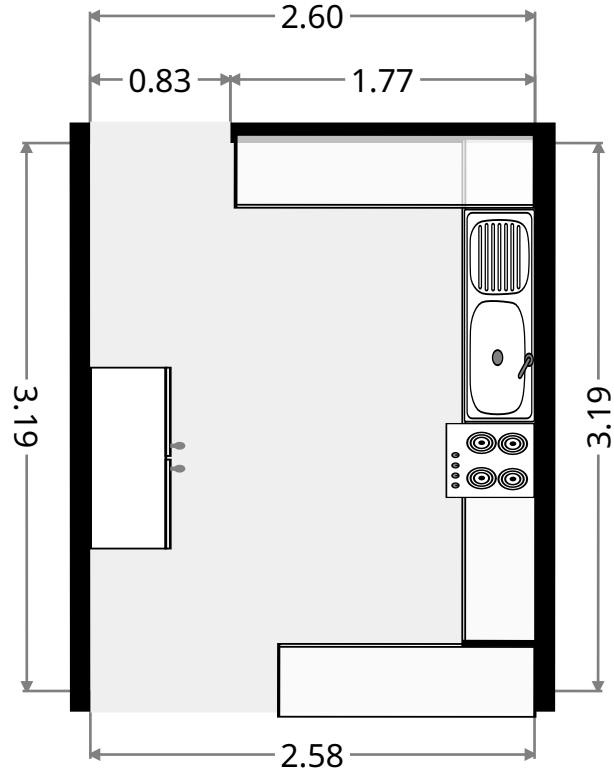
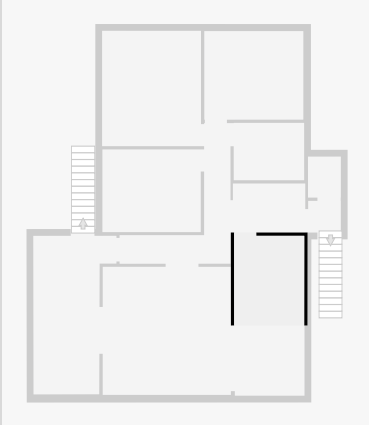

Hall

Width: 1.81 m
 Length: 2.69 m
 Area: 4.85 m²
 Perimeter: 8.98 m

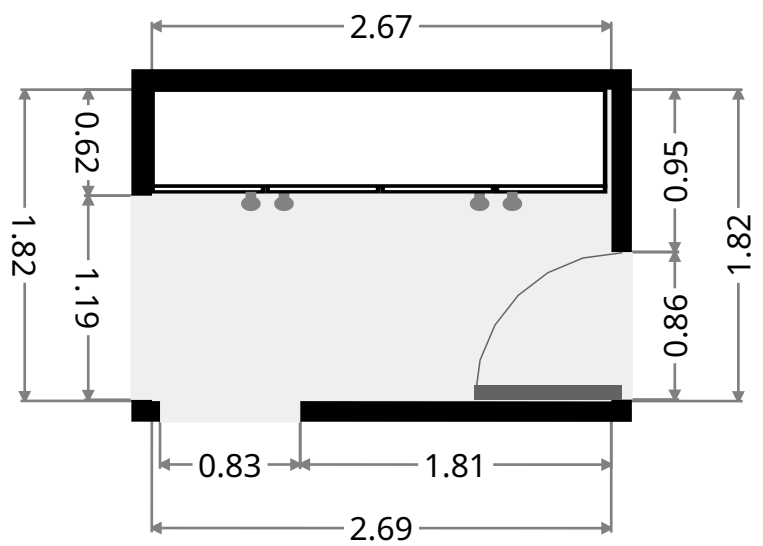
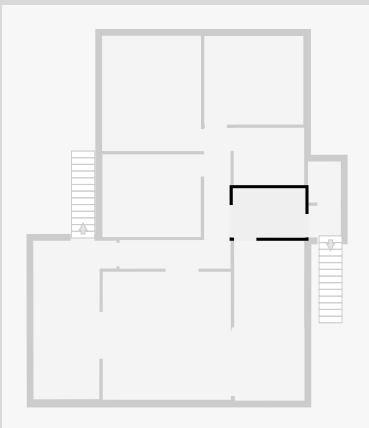

THIS FLOORPLAN IS PROVIDED WITHOUT WARRANTY OF ANY KIND. SENSOPIA DISCLAIMS ANY WARRANTY INCLUDING, WITHOUT LIMITATION, SATISFACTORY QUALITY OR ACCURACY OF DIMENSIONS.

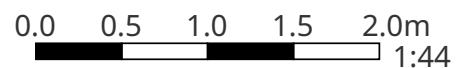

311 Waterloo Street

Toilet

Width: 1.21 m
Length: 1.51 m
Area: 1.84 m²
Perimeter: 5.45 m

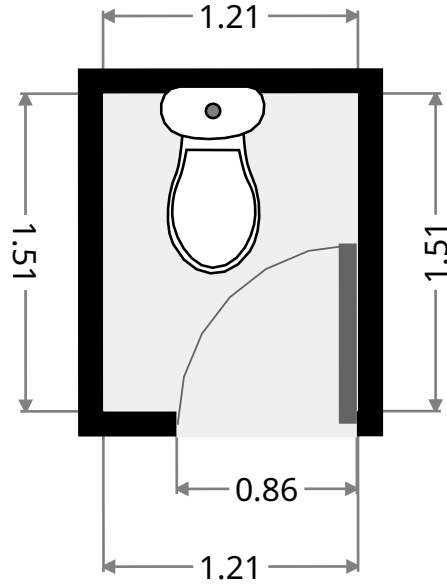
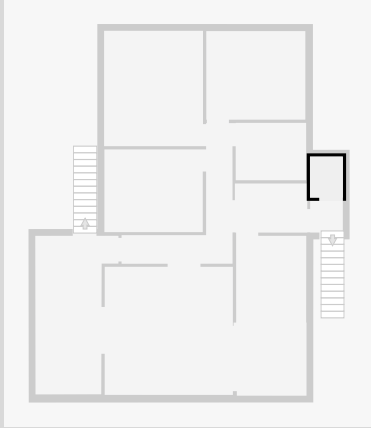

•
Width: 1.17 m
Length: 1.21 m
Area: 1.41 m²
Perimeter: 4.75 m

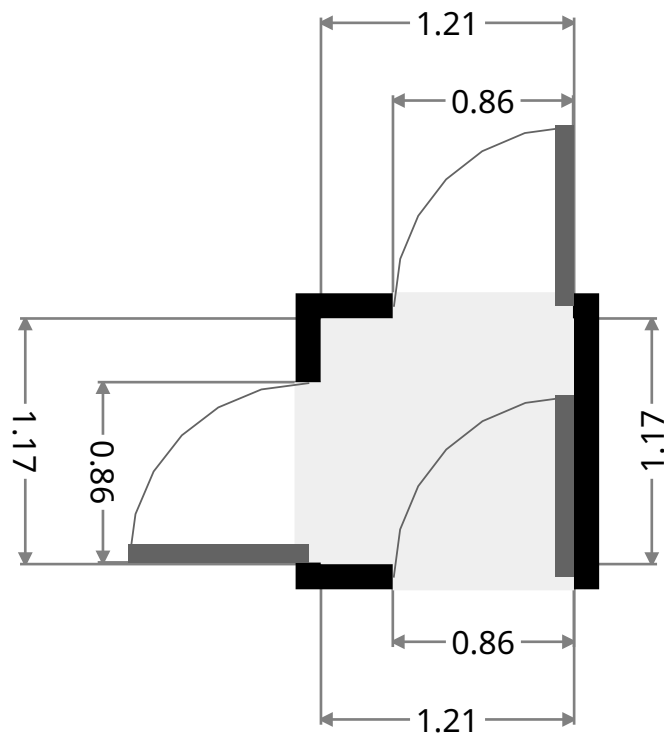
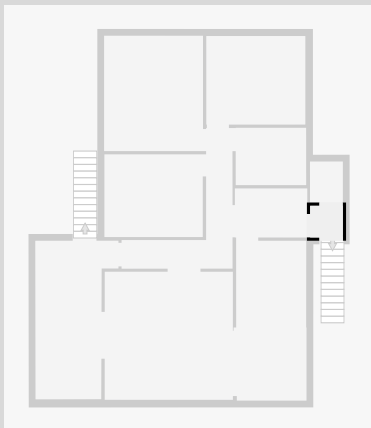

311 Waterloo Street

Bathroom

Width: 2.12 m
Length: 2.60 m
Area: 5.51 m²
Perimeter: 9.44 m

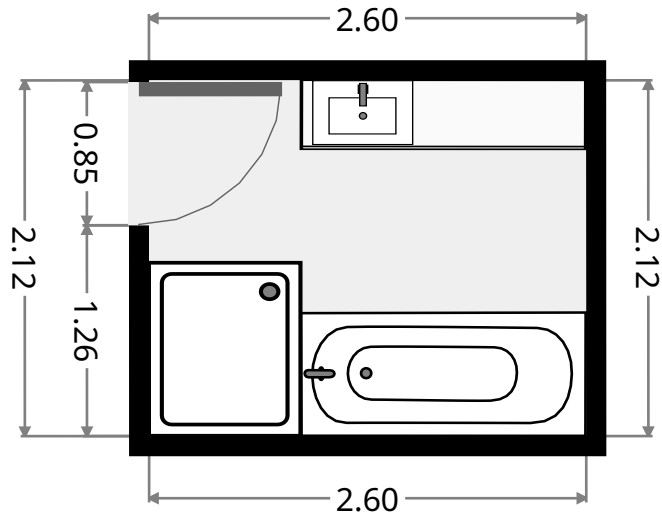
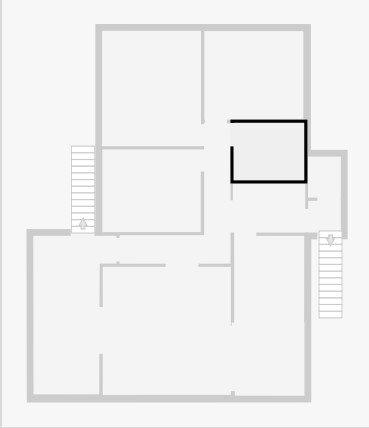

Bedroom

Width: 3.27 m
Length: 3.66 m
Area: 11.97 m²
Perimeter: 13.86 m

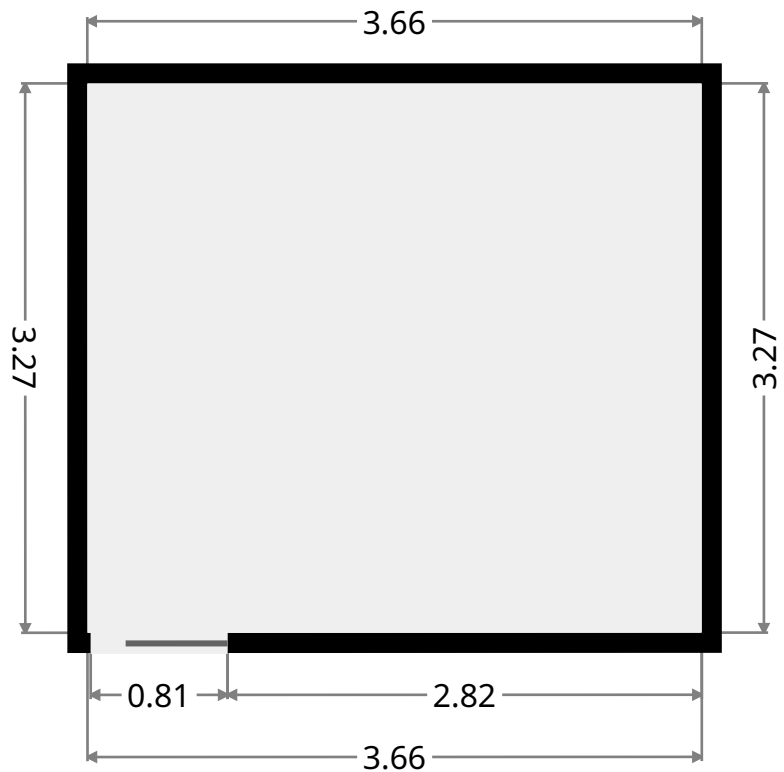
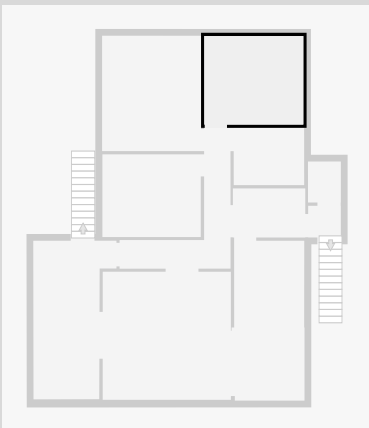

311 Waterloo Street

Master Bedroom

Width: 3.65 m
Length: 4.26 m
Area: 15.56 m²
Perimeter: 15.83 m

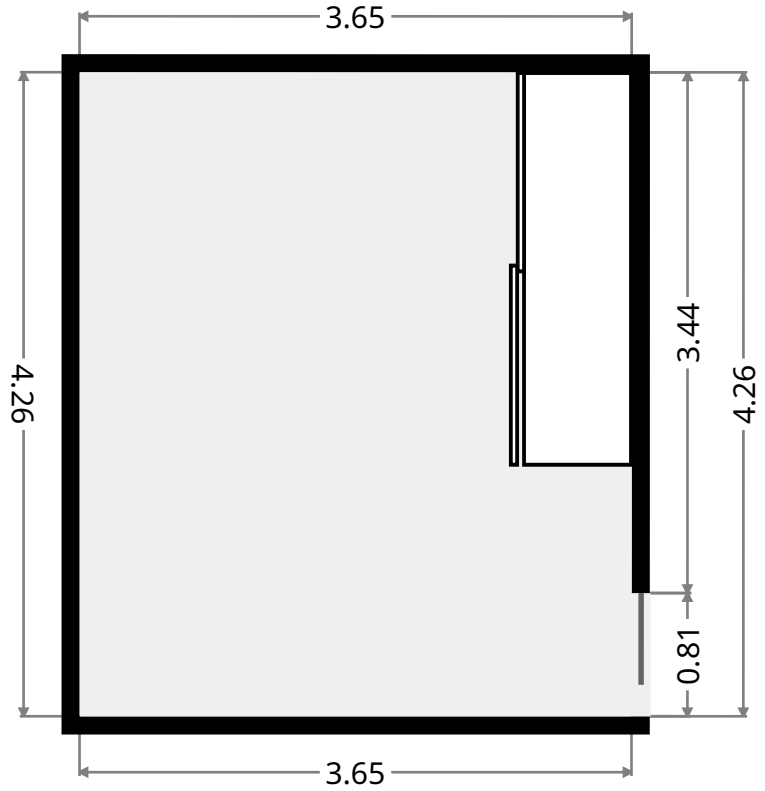
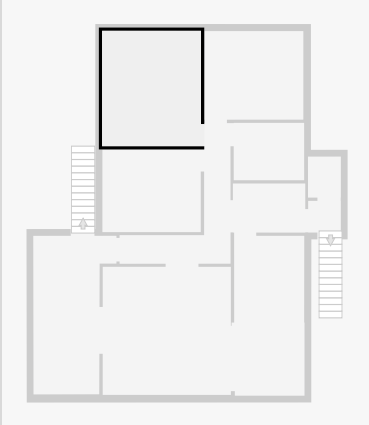

Bedroom

Width: 3.05 m
Length: 3.63 m
Area: 11.09 m²
Perimeter: 13.37 m

